

reflex

Thinking solutions.

Servitec Mini

GB Operating manual

Original operating manual



Visit us at
servitec-mini.com



1	Notes on the operating manual	4
2	Liability and guarantee	4
3	Safety	5
3.1	Personnel requirements	5
3.2	Personal protective equipment	6
3.3	Intended use.....	6
3.4	Inadmissible operating conditions	6
3.5	Residual risks	7
4	Description of the device	8
4.1	Overview	8
4.2	Identification	8
4.3	Function	9
4.4	Scope of delivery.....	9
4.5	Optional equipment and accessories	10
5	Technical data	10
6	Installation	11
6.1	Incoming inspection.....	12
6.2	Preparatory work	12
6.3	Connection.....	13
6.4	Execution.....	13
6.4.1	Installation of the isolation valves	14
6.4.2	Wall mounting	15
6.4.3	Hydraulic connection.....	16
7	Commissioning	17
7.1	Requirements for initial commissioning	17
7.2	Adjusting the filling pressure of the system	17
7.3	Commissioning	18
7.4	Installation and commissioning certificate.....	18

8	Operation	19
	8.1 Automatic mode	19
	8.2 Stop mode.....	19
	8.3 Restarting.....	19
9	Controller	20
	9.1 Operator panel	20
	9.2 Messages.....	21
	9.3 Reset	22
10	Maintenance	22
	10.1 Maintenance schedule	23
	10.2 Cleaning	24
11	Disassembly	25
12	Disposal	26
13	Annex	27
	13.1 Reflex Customer Service	27
	13.2 Conformity and standards.....	27
	13.3 Guarantee	27

1 Notes on the operating manual

This operating manual is an important aid for ensuring the safe and reliable functioning of the device. Reflex Winkelmann GmbH accepts no liability for any damage resulting from failure to observe the information in this operating manual. In addition to the requirements set out in this operating manual, national statutory regulations and provisions in the country of installation must also be complied with (concerning accident prevention, environment protection, safe and professional work practices, etc.).



Notice!

Every person installing this equipment or performing any other work at the equipment is required to carefully read this operating manual prior to commencing work and to comply with its instructions. The manual is to be provided to the product operator and must be stored near the product for access at any time.

2 Liability and guarantee

The device has been built according to the state of the art and recognised safety rules. Nevertheless, its use can pose a risk to life and limb of personnel or third persons as well as cause damage to the system or other property.

It is not permitted to make any modifications at the device, such as to the hydraulic system or the circuitry.

The manufacturer shall not be liable nor shall any warranty be honoured if the cause of any claim results from one or more of the following causes:

- Improper use of the device.
- Unprofessional commissioning, operation, service, maintenance, repair or installation of the device.
- Failure to observe the safety information in this operating manual.
- Operation of the device with defective or improperly installed safety/protective equipment.
- Opening the housing of the electrical controller.
- Failure to perform maintenance and inspection work according to schedule.
- Use of unapproved spare parts or accessories.

Prerequisite for any warranty claims is the professional installation and commissioning of the device.



Note!

Arrange for specialist personnel to carry out commissioning and annual maintenance.

3 Safety

The following symbols and signal words are used in this operating manual.

DANGER

Danger of death and/or serious damage to health

- The sign, in combination with the signal word 'Danger', indicates imminent danger; failure to observe the safety information will result in death or severe (irreversible) injuries.

WARNING

Serious damage to health

- The sign, in combination with the signal word 'Warning', indicates imminent danger; failure to observe the safety information can result in death or severe (irreversible) injuries.

CAUTION

Damage to health

- The sign, in combination with the signal word 'Caution', indicates danger; failure to observe the safety information can result in minor (reversible) injuries.

ATTENTION

Damage to property

- The sign, in combination with the signal word 'Attention', indicates a situation where damage to the product itself or objects within its vicinity can occur.



Note!

This symbol, in combination with the signal word 'Note', indicates useful tips and recommendations for efficient handling of the product.

3.1 Personnel requirements

Only specialist personnel or specifically trained personnel may install and operate the equipment. The electric connections and the wiring of the device must be executed by a specialist in accordance with all applicable national and local regulations.

3.2 Personal protective equipment



Use the prescribed personal protective equipment as required (e.g. ear protection, eye protection, safety shoes, helmet, protective clothing, protective gloves) when working at the system in which the device is installed.

Information on personal protective equipment requirements is set out in the relevant national regulations of the respective country of operation.

3.3 Intended use

The device is used in facility systems for stationary heating and cooling circuits. The devices may be used only in systems that are sealed against corrosion and with the following water types:

- Non-corrosive.
- Chemically non-aggressive.
- Non-toxic.

Minimise the entry of atmospheric oxygen throughout the facility system and into the make-up water.



Note!

Ensure the quality of the make-up water as specified by national regulations.

- For example, VDI 2035 or SIA 384-1.

3.4 Inadmissible operating conditions

The device is not suitable for the following applications:

- Outdoor operation.
- For use with mineral oils.
- For use with flammable media.
- For use with distilled water.
- For use with fully desalinated water.



Note!

It is not permitted to make any modifications to the hydraulics or the circuitry.

3.5 Residual risks

The device has been manufactured using state-of-the-art technology. Despite this, residual risks cannot be excluded.

WARNING

Risk of fire due to open ignition sources

The device housing is made of combustible material and is heat-sensitive.

- Avoid heat and ignition sources (flames or sparks).

CAUTION

Risk of burns on hot surfaces

Hot surfaces in heating systems can cause burns to the skin.

- Wear protective gloves.
- Please place appropriate warning signs in the vicinity of the device.

CAUTION

Risk of injury due to pressurised liquid

If installation, removal or maintenance work is not carried out correctly, there is a risk of burns and other injuries at the connection points, if pressurised hot water or hot steam suddenly escapes.

- Ensure proper installation, removal or maintenance work.
- Ensure that the system is de-pressurised before performing installation, removal or maintenance work at the connection points.

CAUTION

Risk of injury due to heavy device weight

The device weight may cause physical injury or accidents.

- If necessary, work with a second person during assembly or disassembly.

ATTENTION

Device damage during transport

If the device is not transported correctly, it may be damaged.

- Use suitable covers to protect the connections against damage.

4 Description of the device

The Servitec Mini is a water degassing system for use in small systems of up to 1 m³ system volume.

4.1 Overview

1	Venting grille
2	Hinge for folding up
3	Controller
4	Gas-rich water inlet
5	Dirt trap
6	Degassed water outlet
7	Folds up in the direction of the arrow

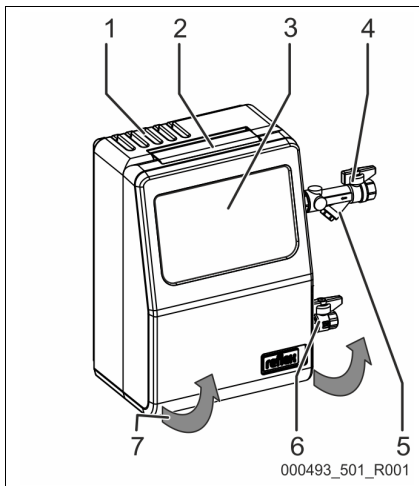

4.2 Identification

The nameplate provides information on manufacturer, year of manufacture, part number and technical data. The nameplate is located on the rear side of the controller inside the system.

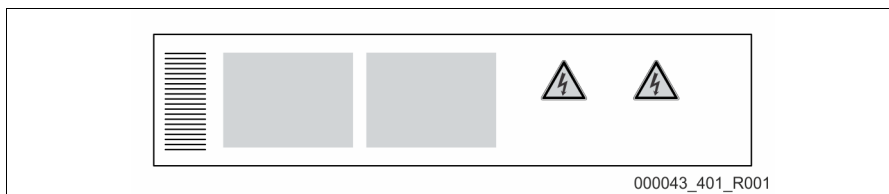

Information on the type plate	Meaning
Type	Device name
Serial No.	Serial number
min. / max. allowable pressure P	Minimum/maximum permissible pressure
min. / max. continuous operating temperature	Minimum/maximum continuous operation temperature
Year built	Year of manufacture

4.3 Function

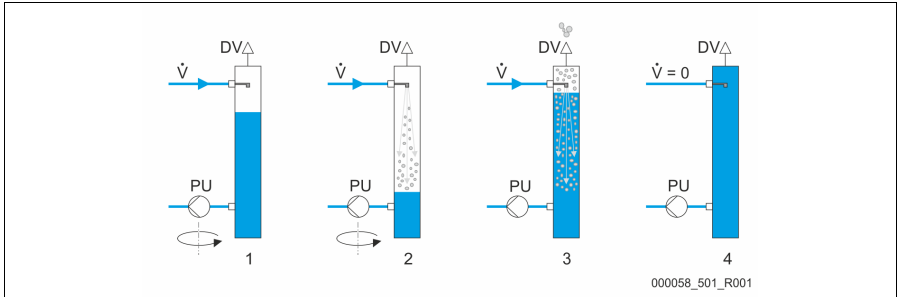

1	Vacuum is drawn
2	Injection

3	Discharge
4	Idling time

The Reflex Servitec Mini can degas the system water in a spray tube. Gas-rich water is sprayed into the spray tube via a nozzle. A pump sucks the water out of the spray tube and transports it into the system. The system is set up so that the pump draws more water from the pipe that can flow through the nozzle. The result is a vacuum in the spray tube, that causes the degassing effect. When the pump switches off, water flows into the spray tube and pushes the driven out gas to the outside via a special valve.

4.4 Scope of delivery

The scope of delivery is described in the shipping document for the initial shipment and the content is shown on the packaging.

Immediately after receipt of the goods, please check the shipment for completeness and damage. Please notify us immediately of any transport damage.

Basic degassing equipment:

- Device
- 2 ball valves for the degassing connections
- Operating manual
- Drilling template and set of screws for wall mounting

4.5 Optional equipment and accessories

The following optional equipment and accessories are available for use with this device:

- Fillcontrol Plus Compact with external pressure sensor for make-up with water.
- Fillsoft/Fillsoft zero for softening/desalinating the make-up water from the potable water system.



Note!

Separate operating manuals are supplied with accessories.



Note!

Connection to the heating or chilled water system must be performed externally.

5 Technical data

Permissible flow temperature:	60 °C
Permissible ambient temperature:	0 °C - 45 °C
Permissible operating overpressure:	4.0 bar
Degree of discharge, dissolved gases:	≤ 90 %
Degree of discharge, free gases:	100 %
Degree of protection:	IP 54
Electrical power:	60 W
Electrical supply:	230 V; 50 Hz
Electrical current consumption:	0.3 A
Electrical voltage control unit:	230 V
Sound pressure level:	55 dB
Weight:	5.6 kg
Height:	420 mm
Width:	295 mm
Depth:	220 mm
Connection:	1/2 "
System volume:	1 m ³
Operating pressure:	0.5 - 2.5 bar
Permissible operating overpressure:	4 bar
Max. permissible operating temperature:	60 °C

6 Installation

DANGER

Risk of serious injury or death due to electric shock.

If live parts are touched, there is risk of life-threatening injuries.

- Ensure that the supply cable to the device is disconnected and secured against being switched back on.
 - Ensure that the system is secured and cannot be reactivated by other persons.
 - Ensure that installation work for the electric connection of the device is carried out by an electrician, and in compliance with electrical locally applicable electrical engineering regulations.
-

CAUTION

Risk of injury due to pressurised liquid

If installation, removal or maintenance work is not carried out correctly, there is a risk of burns and other injuries at the connection points, if pressurised hot water or hot steam suddenly escapes.

- Ensure proper installation, removal or maintenance work.
 - Ensure that the system is de-pressurised before performing installation, removal or maintenance work at the connection points.
-

CAUTION

Risk of burns on hot surfaces

Hot surfaces in heating systems can cause burns to the skin.

- Wear protective gloves.
 - Please place appropriate warning signs in the vicinity of the device.
-

CAUTION

Risk of injury due to falls or bumps

Bruising from falls or bumps on system components during installation.

- Wear personal protective equipment (helmet, protective clothing, gloves, safety boots).
-

Note!

Confirm that installation and start-up have been carried out correctly using the installation and commissioning certificate. This action is a prerequisite for the making of warranty claims.

- Have the Reflex Customer Service carry out commissioning and the annual maintenance.

6.1 Incoming inspection

Prior to shipping, this device was carefully inspected and packed. Damages during transport cannot be excluded.

Proceed as follows:

1. Upon receipt of the goods, check the shipment for
 - completeness and
 - possible transport damage.
2. Document any damage.
3. Contact the forwarding agent to register your complaint.

6.2 Preparatory work

Condition of the delivered device:

- Check all screw connections of the device for tight seating. Tighten the screws as necessary.

Preparing the connection of the device to the plant system:

- Barrier-free access to the plant system.
- Level and solid installation surface for the device.
- Frost-free, well-ventilated room.
 - Room temperature > 0 - 45 °C.
- Electric connection.
 - 230 V~, 50 Hz, 16 A with upstream ELCB (tripping current: 0.03 A).

6.3 Connection

Basic system variant Servitec Mini

1	Servitec Mini
2	Gas-rich water
3	Degassed water

- Connection 2 x DN 15
- Max. pipe length 5m

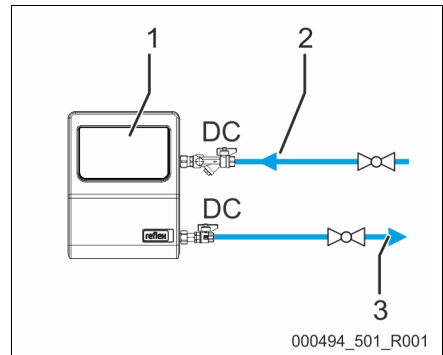

- ▶ **Note!**
Shut-off valves must be used at the connection point to the pipe network.
- ▶ **Note!**
We recommend connection to the existing pipe network using a flexible hose connection (especially in buildings with high noise abatement requirements).

6.4 Execution

- ▶ **Note!**
The screw connections at the device may loosen when the device is moved to another location.
 - Prior to using the device check the screw connections for proper seating and sealing.
- ▶ **Note!**
Avoid leaks at the connections.
 - When connecting the device to the facility system, ensure that the connections for degassing and make-up are not twisted.

Proceed as follows:

- Connect the device on the return side of the system.
 - In this manner, you ensure that the device is operated within the permissible pressure and temperature ranges.
- In the case of a system with return flow admixture or a hydraulic switching point, connect the device upstream of the switching point.
 - In doing so, you guarantee water degassing in the "V" main volume flow at temperatures $\leq 60\text{ }^{\circ}\text{C}$.

CAUTION – damage due to improper connection! Bear in mind that the device may be subject to additional loads through the connection of piping or hose connections to the system. Ensure that all connections to the system are free from stresses. If necessary, provide support structures for the pipes.

CAUTION – Damage to property caused by leaks! Leaks in the connection pipes to the device can cause damage to property within the system. Use only connection pipes with adequate resistance against the system temperature.

Proceed as follows:

- 1 Mount the device on the wall, see chapter 6.4.3 "Hydraulic connection" on page 16 .
- 2 Complete the water side connections from the device to the system, .



Note!

When connecting, ensure the valves and supply element options of the connecting pipes can be operated.

6.4.1 Installation of the isolation valves

1	Isolation valve with filter insert
2	Isolation valve
3	Connection pipe

The connection pipes (3, blue) are pre-assembled in the factory. The shut-off valves (1) and (2) are fitted to the device on-site prior to wall mounting.

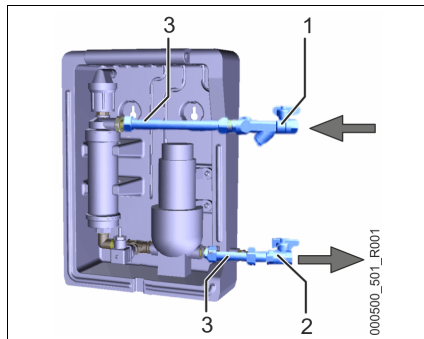

6.4.2 Wall mounting

ATTENTION

Damage due to sound and noise transfer to building parts

- Do not install the device on false or stud walls that could act as a sound box or resonating body.

1	Drilling template
2	Set of screws

Use the holes provided at the rear of the housing to attach the device at the wall. Dependent on the wall properties, the fastening materials must be checked and if necessary adapted prior to installation.

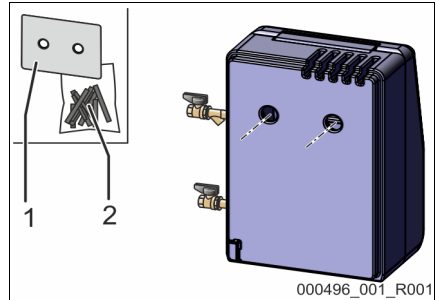

Note!

Use the enclosed drilling template and set of screws for wall mounting.

1. Attach the drilling template to the wall with sticky tape.
2. Drill the holes for attaching the device
3. Remove the drilling template.
4. Hang the device on the wall.

6.4.3 Hydraulic connection

Install the 'DC' degassing pipes as shown below:

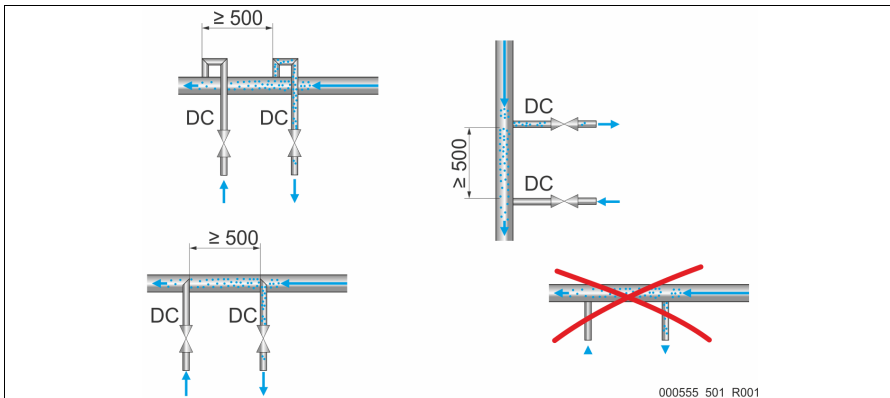

Comply with the following points:

- Prevent overloading of the dirt trap in the device resulting from coarse dirt.
- Install the gas-rich degassing line upstream of the gas-poor degassing line (when viewed in the system flow direction).
- Preferably install on the return side of the system.
 - The water temperature must be in the range of 0 °C – 60 °C to ensure sufficient degassing capacity.

7 Commissioning

**Note!**

Arrange for specialist personnel to carry out commissioning and annual maintenance.

7.1 Requirements for initial commissioning

The device will be ready for commissioning when the tasks described in the "Installation" chapter have been completed.

- The device is securely mounted.
- The connections of the device to the system have been created and plant system pressure maintenance is operational.
 - One degassing pipe to the plant system (device outlet).
 - One degassing pipe from the plant system (device inlet).
- If required, the connection pipes of the device have been purged and cleaned of welding residue and dirt prior to commissioning.
- The plant system is filled with water and the majority of the gas has been vented.
 - Circulation through the entire plant system is thus ensured.

7.2 Adjusting the filling pressure of the system

Before the Servitec Mini is commissioned, the system must be filled. The volume of the Servitec Mini must be allowed for in the system. Proceed as follows:

- 1 Open the device ball valves.
 - Water flows in and air escapes via the degassing valve.
- 2 Determine the filling pressure for the system:
 - Filling pressure "pF": $pF[\text{bar}] = p_0 + 0.3 \text{ bar}$
 - Prepressure "pF": $pF[\text{bar}] = p_{\text{stat}} + 0.2 \text{ bar}$
 - Static pressure "pstat": $p_{\text{stat}}[\text{bar}] = \text{Height}[\text{metre}] / 10$
- 3 Check the filling pressure of the system.
- 4 Fill the system with water.
 - Until the necessary filling pressure is reached.

7.3 Commissioning

Link the device to the voltage supply:

- 1 Connect the device plug-in contact to the voltage supply.
- 2 Press "Auto" on the controller's operator panel.

Note!

The system pressure is automatically measured by the integrated pressure sensor.

- During commissioning the Servitec Mini always measures the actual system pressure and generates a message if the pressure is less than the target system pressure by more than 0.3 bar.
- If the system pressure is less than 0.5 bar, a low water error is triggered. Increase the system pressure accordingly.

Note!

We recommend rechecking of the pressure maintenance target value (system pressure) 2 weeks after commissioning of the Servitec Mini and if necessary, replenishing of the system.

7.4 Installation and commissioning certificate

Note!

The installation and commissioning certificate can be found at the end of the operating manual.

8 Operation

8.1 Automatic mode

Automatic mode includes the two operating modes continuous degassing and interval degassing.

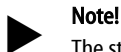
**Note!**

The starting time of the degassing processes is specified based on the time at the very first start.

To reset and for new setting of the start time, see chapter 9.3 "Reset" on page 22 .

Continuous degassing

This mode is started during first commissioning by pressing the Auto button. Multiple degassing cycles without pause times are carried out over a fixed period of several hours during the day. The daily start time is set based on the time of the initial commissioning.

Interval degassing

This mode comprises repeating intervals. There is a pause time between the intervals. Once continuous degassing has completed, interval degassing starts automatically.

8.2 Stop mode

On the controller, press 'Stop' to activate stop mode. The Auto LED of the control panel goes out, the Stop LED lights up.

Except for the display of information, the device is non-functional in Stop mode. Function monitoring is stopped. The vacuum pump is switched off.

**Note!**

The system triggers an error message if Stop mode is activated for more than 4 hours.

8.3 Restarting

**Note!**

Recommissioning after a long shut-down takes place by pressing the 'Auto' button.

9 Controller

9.1 Operator panel

1	Degassing LED <ul style="list-style-type: none"> Lights up green during the injection function, .
2	Water level LED <ul style="list-style-type: none"> Lights up red if a warning exists
3	Pump LED <ul style="list-style-type: none"> Lights up green during operation
4	Stop button/LED <ul style="list-style-type: none"> For stop mode Lights up yellow
5	Auto button/LED <ul style="list-style-type: none"> For continuous operation Acknowledge error messages Lights up green
6	Error LED <ul style="list-style-type: none"> Lights up red if an error exists

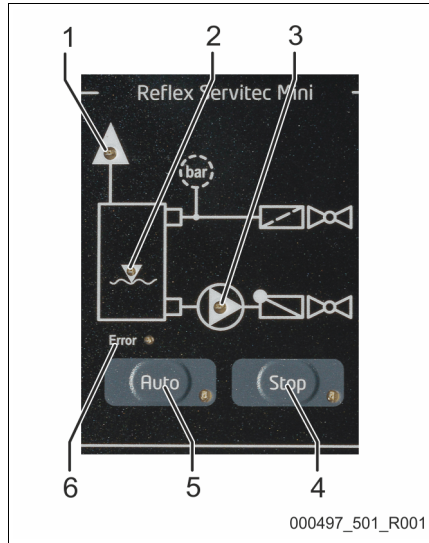

9.2 Messages

If errors occur during operation of the system, these are visualised via the Error LED in combination with other LEDs.

- Errors must be acknowledged with the Auto button.
 - Until acknowledgement, the system remains in the error state.
- Warnings need not be acknowledged. The system continues to run.
 - As soon as the cause of the warning is cleared, the corresponding LED goes out.

Error table

ER Code	Error	Cause	Remedy
02.1	Error LED and Water level LED light up (low water)	<ul style="list-style-type: none"> • Dirt trap clogged. • Incoming pipe shut-off. • Insufficient pressure in the vacuum pump. 	<ul style="list-style-type: none"> • Clean the dirt trap. • Unblock the incoming pipes.
08	Error LED lights up	<ul style="list-style-type: none"> • Parted cable. <ul style="list-style-type: none"> – No connection of the sensor to the circuit board. 	<ul style="list-style-type: none"> • Check the cable connection. • Replace defective component.
14	Error LED and Degassing LED light up (discharge period)	<ul style="list-style-type: none"> • Degassing degassing line • Dirt trap clogged. • Set value exceeded. 	<ul style="list-style-type: none"> • Open the degassing line. • Clean the dirt trap.
19	Error LED lights up and stop LED flashes (Stop \geq 4 hours)	Device is in stop mode for more than 4 hours.	Set the controller to Automatic mode.

Warnings

(System continues to run)

ER Code	Error	Cause	Remedy
01	Water level LED and Auto LED light up (Minimum pressure)	<ul style="list-style-type: none"> • Water loss in the system. • Vacuum pump fault. • Expansion vessel defective. 	<ul style="list-style-type: none"> • Check water level. • Check vacuum pump. • Check expansion vessel.
10	Error LED flashes (maximum pressure)	The pressure exceeds the maximum pressure of 2.5 bar.	Lower the pressure at the transducer.

9.3 Reset

You can perform a reset if there is a need to reset the system to factory settings.

1. Ensure that the system is in stop mode.
2. Simultaneously press the Auto button and the Stop button for longer than 5 seconds. All LEDs flash briefly.
3. Release the stop and auto buttons again.
The reset is performed and the device commences the start routine.

Note!

After the reset, the continuous degassing and interval degassing operating times are automatically synchronised from this new point in time, see chapter 8.1 "Automatic mode" on page 19.

10 Maintenance

CAUTION

Risk of burns on hot surfaces

Hot surfaces in heating systems can cause burns to the skin.

- Wear protective gloves.
 - Please place appropriate warning signs in the vicinity of the device.
-

CAUTION

Risk of injury due to pressurised liquid

If installation, removal or maintenance work is not carried out correctly, there is a risk of burns and other injuries at the connection points, if pressurised hot water or hot steam suddenly escapes.

- Ensure proper installation, removal or maintenance work.
 - Ensure that the system is de-pressurised before performing installation, removal or maintenance work at the connection points.
-

The 'Servitec' must be serviced annually.

Note!

Maintenance work must only be carried out and confirmed by specialist personnel.

10.1 Maintenance schedule

The maintenance schedule is a summary of maintenance tasks to be carried out regularly.

Activity	Check	Wait	Clean	Interval
Check the leak tightness <ul style="list-style-type: none"> • Screw connections • Degassing valve 	x	x		Annually
Function test of the vacuum pump. <ol style="list-style-type: none"> 1. Press and hold the Stop button for at least 2 seconds. <ul style="list-style-type: none"> – The pump continues running. – Allow the pump to run for not more than 30 seconds. 2. Wait two minutes 3. The process can be repeated by pressing the button again. 	x			Annually
Clean the dirt trap, see chapter 10.2 "Cleaning" on page 24	x	x	x	Dependent on the operating conditions

10.2 Cleaning

Cleaning the dirt trap

The dirt trap in the degassing line must be cleaned no later than after the expiry of the continuous degassing time. Check the dirt traps after every filling process or extended operation.

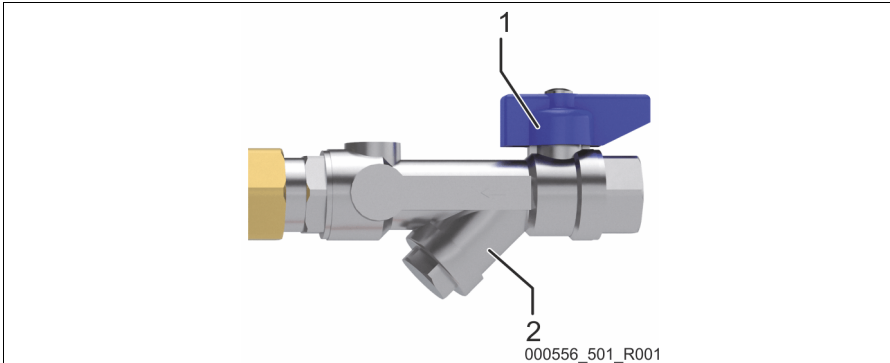

1. Press 'Stop' on the control panel of the controller.
 - The device is non-functioning and the vacuum pump is shut down.
2. Close the ball valve (1) upstream of the dirt trap (2).
3. Slowly unscrew the cap with the strainer.
 - The residual pressure in the pipe segment is released.
4. Pull the strainer out of the cap.
5. Clean the strainer with a soft brush and rinse it with clear water.
6. Check the seal for damage and replace as necessary.
7. Insert the sieve in the cap and turn the cap with the sieve in the housing of the dirt trap (2).
8. Open the ball valve (1) upstream of the dirt trap (2).
9. Press 'Auto' on the control panel of the controller.
 - The device is switched on and the vacuum pump is in operation.

11 Disassembly

DANGER

Risk of serious injury or death due to electric shock.

If live parts are touched, there is risk of life-threatening injuries.

- Ensure that the supply cable to the device is disconnected and secured against being switched back on.
 - Ensure that the system is secured and cannot be reactivated by other persons.
 - Ensure that installation work for the electric connection of the device is carried out by an electrician, and in compliance with electrical locally applicable electrical engineering regulations.
-

CAUTION

Risk of burns

Escaping hot medium can cause burns.

- Maintain a sufficient distance from the escaping medium.
 - Wear suitable personal protective equipment (safety gloves and goggles).
-

CAUTION

Risk of burns on hot surfaces

Hot surfaces in heating systems can cause burns to the skin.

- Wear protective gloves.
 - Please place appropriate warning signs in the vicinity of the device.
-

CAUTION

Risk of injury due to pressurised liquid

If installation, removal or maintenance work is not carried out correctly, there is a risk of burns and other injuries at the connection points, if pressurised hot water or hot steam suddenly escapes.

- Ensure proper installation, removal or maintenance work.
 - Ensure that the system is de-pressurised before performing installation, removal or maintenance work at the connection points.
-

CAUTION

Risk of injury when upon coming into contact with glycol containing water

Contact with glycol containing water in plant systems for cooling circuits can result in irritation of the skin and eyes.

- Use personal protective equipment (safety clothing, gloves and goggles, for example).
-

Prior to disassembly, shut off the degassing pipes from the system to the device and de-pressurise the device. Then disconnect the device from all electrical power sources.

Proceed as follows:

1. Set the device controller to stop mode.
2. Close the connections from the device for the degassing pipes.
3. Disconnect the device from all electrical power sources.
4. Disconnect the power cable of the device from the power supply.
5. Secure the plant system to prevent it being switched back on.



DANGER – Risk of serious injury or death due to electric shock. Some parts of the device's circuit board may still carry 230 V voltage even with the device physically isolated from the power supply. Before you remove the covers, completely isolate the device controller from the power supply. Verify that the main circuit board is voltage-free.

6. Remove the degassing pipes from the device.
 - Ensure that the device shut-offs are not twisted when you remove the pipes.
 - Slowly disconnect the pipes and if necessary catch any escaping residual water in a container.
7. Physically remove the device from the system.
8. Drain all residual water from the device.
 - At the device, open the connections for the degassing pipes.
 - Use a suitable container to catch the residual water.

The device is removed.

12 Disposal

The intentional or unintentional reuse of used components can result in a hazard for persons, the environment and the system.

Therefore, please observe the following points:

- The operating company is responsible for proper disposal.
- Only to be disposed of by specialist personnel.
- Upon conclusion of the useful life, strip the system down into different separable materials and deliver to a specialist company for recycling.



Note!

The following included materials are fully recyclable:

- EPP (housing)
- ABS (front cover of the controller)
- PP (back cover of the controller)

13 Annex

13.1 Reflex Customer Service

Central customer service

Central telephone number: +49 (0)2382 7069 - 0

Customer Service extension: +49 (0)2382 7069 - 9505

Fax: +49 (0)2382 7069 - 9523

E-mail: service@reflex.de

Technical Hotline

For questions about our products

Telephone number: +49 (0)2382 7069-9546

Monday to Friday 8:00 to 16:30

13.2 Conformity and standards

Device conformity declarations are available on the Reflex homepage.

www.reflex-winkelmann.com/konformitaetserklaerungen

Alternatively, scan the QR code:

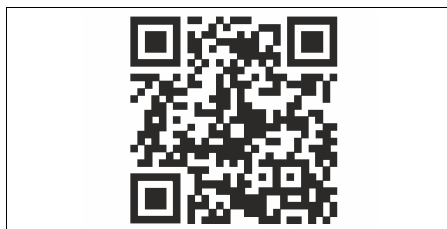

13.3 Guarantee



The respective statutory guarantee regulations apply.

EN **Installation and commissioning certificate** - This device has been installed and commissioned in accordance with the instructions provided in the operating manual. The settings in the controller match the local conditions.





Typ / Type:	
P ₀	
P _{SV}	
Fabr. Nr. / Serial-No.	





reflex

Thinking solutions.

Reflex Winkelmann GmbH
Gersteinstraße 19
59227 Ahlen, Germany



+49 (0)2382 7069-0

+49 (0)2382 7069-9546

A **WINKELMANN**
BUILDING+INDUSTRY BRAND

www.reflex-winkelmann.com